



EUROPEAN PATENT APPLICATION

Application number: 86304171.1

Int. Cl.4: **B62D 25/20**

Date of filing: 02.06.86

Date of publication of application:
09.12.87 Bulletin 87/50

Applicant: **HOCKNEY PTY LIMITED**
2-4 Dupas Street
Smithfield New South Wales 2164(AU)

Designated Contracting States:
AT BE CH DE FR GB IT LI LU NL SE

Inventor: **Hockney, Philip Kenneth**
2-4 Dupas Street
Smithfield New South Wales 2164(AU)

Representative: **JENSEN & SON**
8 Fulwood Place High Holborn
London WC1V 6HG(GB)

A table top for a motor lorry.

A motor lorry table top (10) consisting of a plurality of planks (13) which are fixed to at least two beams (11) forming part of the motor lorry chassis, and wherein said planks (13) consist of extruded aluminium and are fixed to the chassis by means of clips (17) with the planks (13) interlocking to secure the planks (13) from relative movement therebetween.

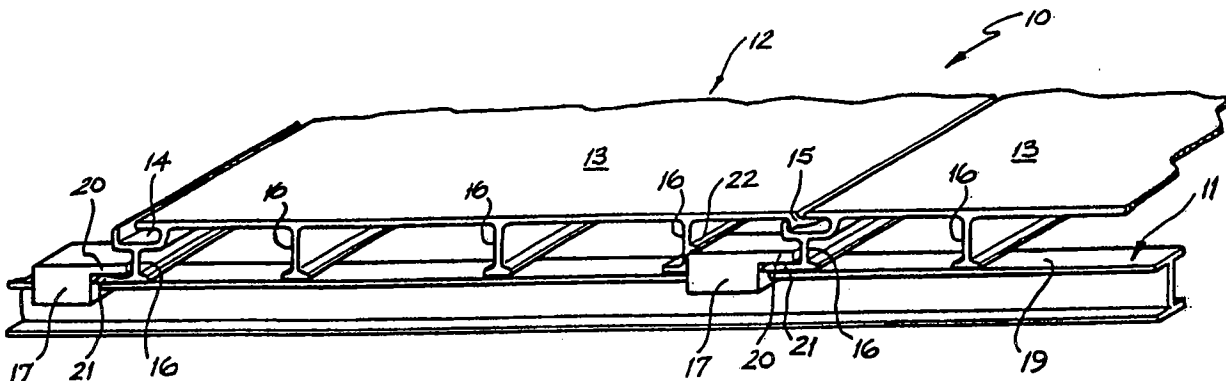

FIG. 1

"A TABLE TOP FOR A MOTOR LORRY"

The present invention relates to the construction of "table tops" for motor lorries.

Traditionally in the manufacture of motor lorry table tops, either timber or sheet metal has been employed. The use of timber has the disadvantage that it is easily damaged and wears rapidly and therefore provides an uneven surface for the table top. When the table tops have been constructed from sheet material, the method of assembly and installation is generally costly. Additionally these sheet metal floors are usually formed of steel and are accordingly heavy.

It is the object of the present invention to overcome or substantially ameliorate the above disadvantages.

There is disclosed herein a table top assembly for a motor lorry, the motor lorry having a chassis including at least two beams which are generally parallel and co-extensive and to which the table top assembly is to be fixed, said table top assembly comprising a plurality of generally planar planks which extend longitudinally generally transverse of said beams and are abutted so as to provide a generally horizontal load receiving surface, each plank having longitudinal parallel co-extensive edges, one of said edges having a recess and the other edge having a tongue matingly received within the recess of the next adjacent plank, and each mating recess and tongue co-operating to prevent relative horizontal movement between adjacent planks in a direction normal to said longitudinal edges, each plank further having longitudinal support portions extending generally transverse of said beams and engaging same so that each plank is supported thereby, and a plurality of clip means attached to said beams and engaging each plank to secure the planks to the beams to prevent relative movement of the planks vertically from said beams.

A preferred form of the present invention will now be described by way of example with reference to the accompanying drawings, wherein:

Figure 1 is a schematic part sectioned perspective view of a portion of the table top of a motor lorry;

Figure 2 is a schematic perspective view of a clip employed in the construction of the table top of Figure 1;

Figure 3 is a schematic side elevation of the planks employed to form the table top of Figure 1; and

Figure 4 is a schematic side elevation of the planks in position and forming the table top of Figure 1.

In Figures 1 to 4 there is schematically depicted a portion 10 of a table top of a motor lorry, the motor lorry has a chassis including longitudinally extending beams 11 to which a table top assembly 12 is fixed. The table top assembly includes a plurality of planks 13 which extend transverse of the beams 11 with each plank having one longitudinal edge provided with a recess 14 and the other longitudinal edge provided with a tongue 15. The recesses 14 and tongues 15 are shaped so as to co-operate in securing adjacent edges of adjacent planks together. Additionally, each plank 13 is provided with flanged support portions 16 which extend transverse of the beams 11 and rest thereon so as to support the planks 13 on the beams 11. Each plank 13 is provided with a planar upper surface so that the upper surface of the table top so formed is uniform and flat.

The planks 13 are secured to the beams 11 by means of clips 17, of which one is illustrated in Figure 2. Each clip 17 is provided with a T-shaped recess 18 shaped so as to fit over the top flange 19 of the beam 11 but allow the clip 17 to slide therealong. The clip 17 is also provided with a projection 20 which fits over a bottom flange 21 of one of the support portions 16. The next adjacent support portion 16 abuts the clip 17 and prevents the clip 17 from longitudinal movement along the beam 11. Still further there is provided a projection 22 which also aids in securing the clips 17 in position by engaging the two thereof.

In assembling the abovedescribed table top, when one plank 13 is secured in position by means of the clips 17, the next adjacent plank 13 has its tongue 15 inserted in the appropriate recess 14 and pivoted in position as illustrated in Figure 3. When inserting the tongue 15, the main projection 23 is inserted in the recess 14, while the plank 13 to be added is inclined to plank 13 which is in position. Thereafter the plank 13 is pivoted, as seen in Fig. 3, until the secondary projection 24 is in position. During this movement, the support portion 16 with its projection 22 engages the clip 17, thereby fixing the clip 17 in position and therefore the associated next adjacent plank 13.

Each clip 17 is inserted in position by sliding it along one of the beams 11.

It is preferred in the construction of the abovedescribed table top, that the planks 13 are formed of extruded aluminium or other suitable material and the clips 17 formed of plastics material.

It should further be appreciated that the beams 11 may also extend transverse of the lorry as opposed to longitudinal of the lorry. The support portion 16 would then extend longitudinally of the lorry.

5

Claims

1. A table top assembly for a motor lorry, the motor lorry having a chassis including at least two beams which are generally parallel and co-extensive and to which the table top assembly is to be fixed, said table top assembly comprising a plurality of generally planar planks which extend longitudinally generally transverse of said beams and are abutted so as to provide a generally horizontal load receiving surface, each plank having longitudinal parallel co-extensive edges, one of said edges having a recess and the other edge having a tongue matingly received within the recess of the next adjacent plank, and each mating recess and tongue co-operating to prevent relative horizontal movement between adjacent planks in a direction normal to said longitudinal edges, each plank further having longitudinal support portions extending generally transverse of said beams and engaging same so that each plank is supported thereby, and a plurality of clip means attached to said beams and engaging each plank to secure the planks to the beams to prevent relative movement of the planks vertically from said beams.

10

15

20

25

30

2. The table top assembly of claim 1 wherein each plank is provided with a flange portion, which flanged portion rests on the beam, and said clip means engages the flanged portions.

35

3. The table top assembly of claim 2 wherein said clip means are slidable along the beams so as to be movable into a position engaging the flanged portions.

40

4. The table top assembly of any one of claims 1 to 3 wherein said tongue has a generally horizontally extending main projection portion and a downwardly extending secondary projection portion, and said recess engages said main projection portion to prevent vertical relative movement between adjacent planks, and engages said secondary projection portion to prevent horizontal relative movement between adjacent planks.

45

5. The table top assembly of any one of claims 1 to 4 wherein said support portions engage said clip means to retain said clip means in position on said beams.

50

55

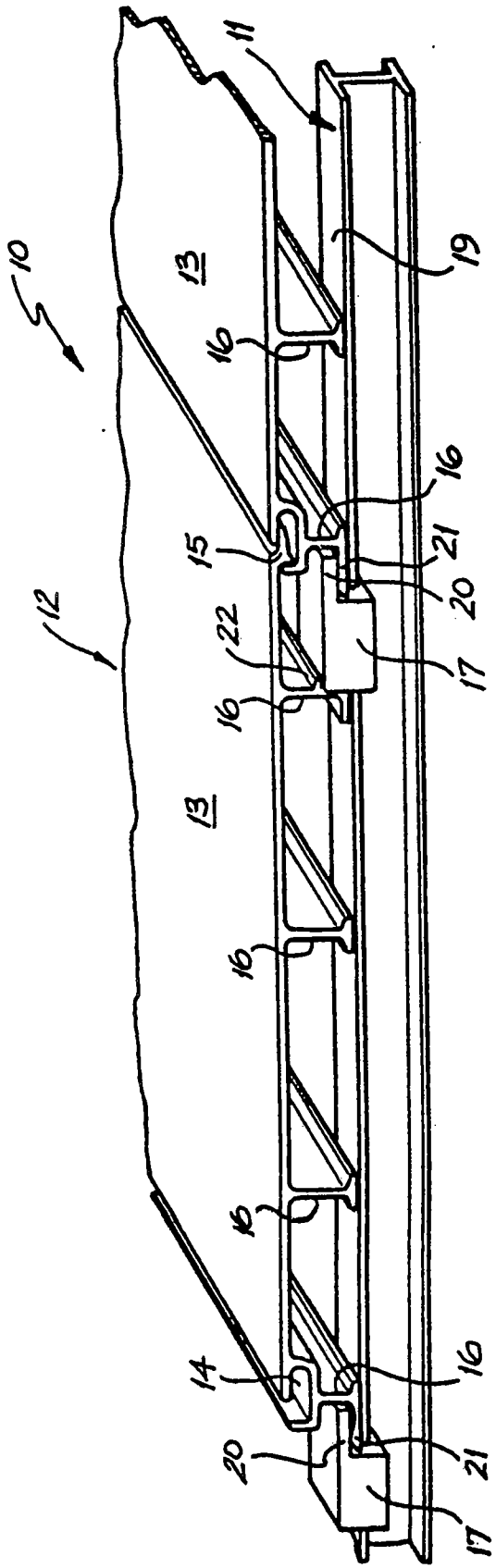

FIG. 1

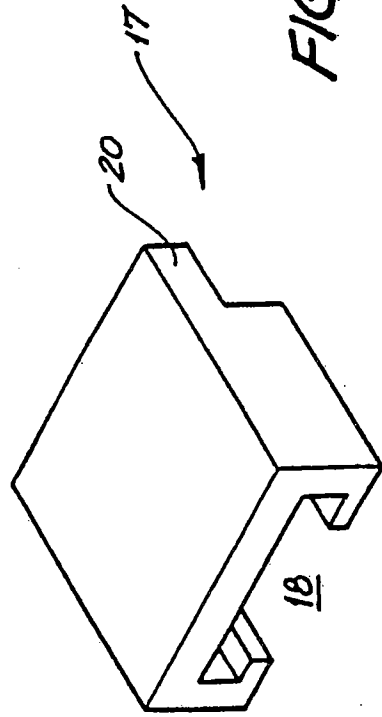

FIG. 2

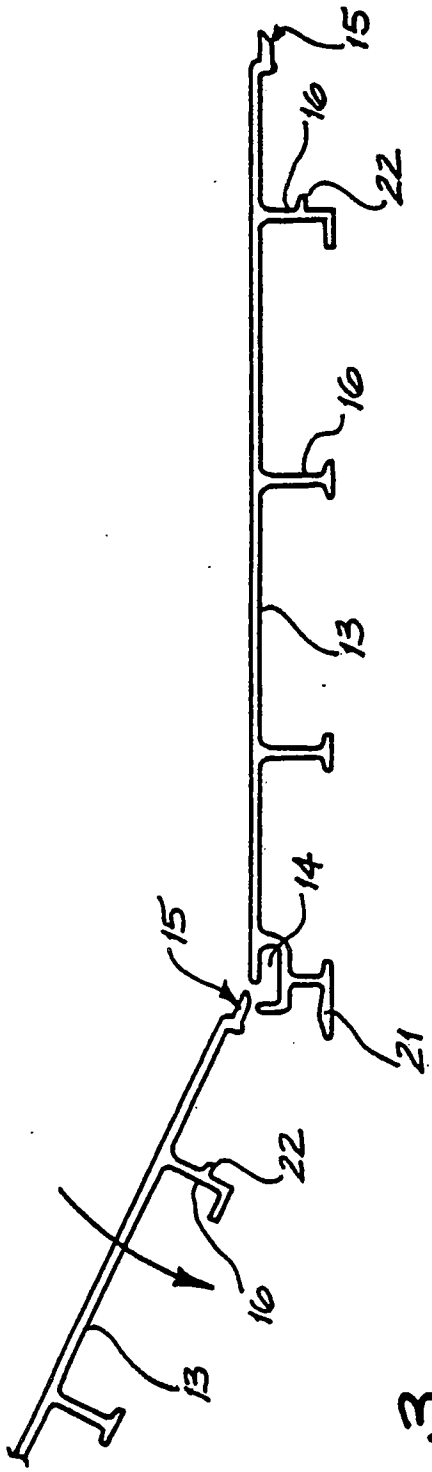

FIG. 3

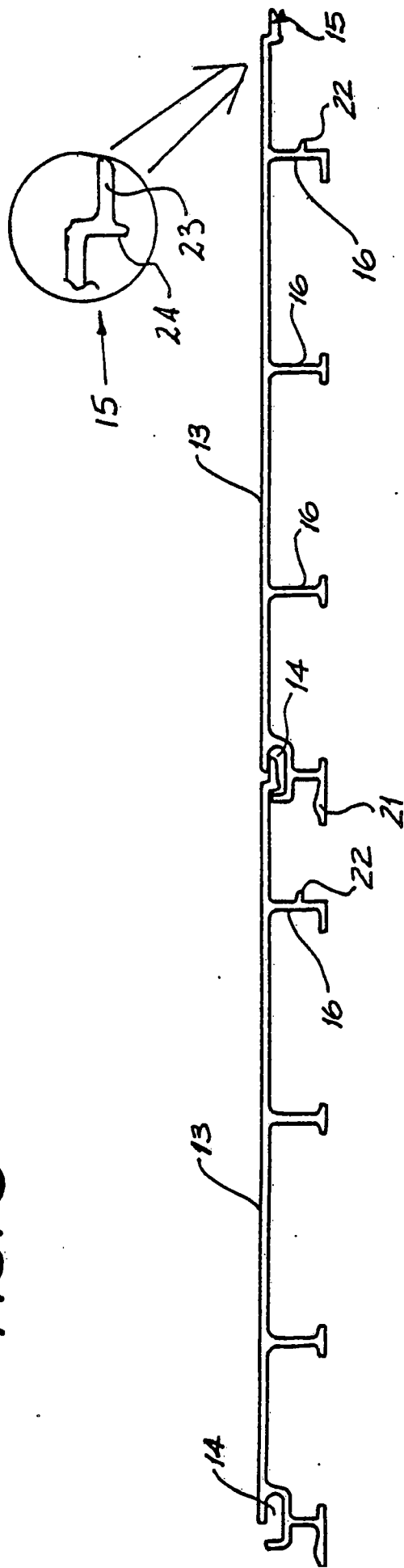

FIG. 4



DOCUMENTS CONSIDERED TO BE RELEVANT			
Category	Citation of document with indication, where appropriate, of relevant passages	Relevant to claim	CLASSIFICATION OF THE APPLICATION (Int. Cl.4)
Y	US-A-4 186 537 (MOUNTZ) * column 2, line 51 - column 3, line 26; figure 2 *	1,2	B 62 D 25/20
A	---	3,4	
Y	US-A-4 266 381 (DELLER) * figures 1, 2 *	1,2	
A	WO-A-8 600 588 (SCHWEIZERISCHE ALUMINIUM) * page 5, lines 6-12; figure 1 * -----	1	
The present search report has been drawn up for all claims			TECHNICAL FIELDS SEARCHED (Int. Cl.4)
			B 62 D 25/00
Place of search	Date of completion of the search	Examiner	
BERLIN	16-01-1987	LUDWIG H J	

CATEGORY OF CITED DOCUMENTS

- X : particularly relevant if taken alone
- Y : particularly relevant if combined with another document of the same category
- A : technological background
- O : non-written disclosure
- P : intermediate document

- T : theory or principle underlying the invention
- E : earlier patent document, but published on, or after the filing date
- D : document cited in the application
- L : document cited for other reasons
- & : member of the same patent family, corresponding document